

WATTCO™

Manufacturer of Electric Heating Elements and Controls

CARTRIDGE HEATERS component parts

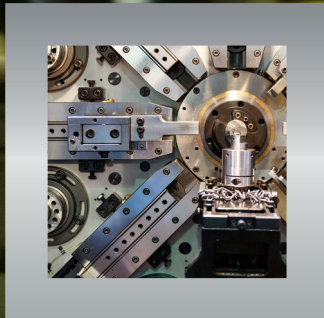
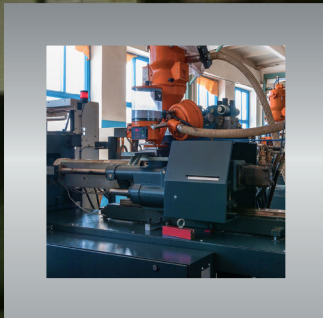
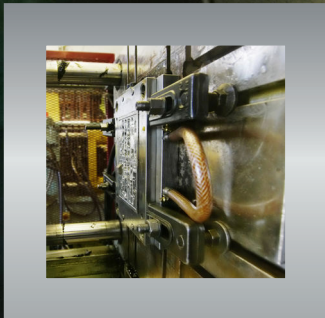
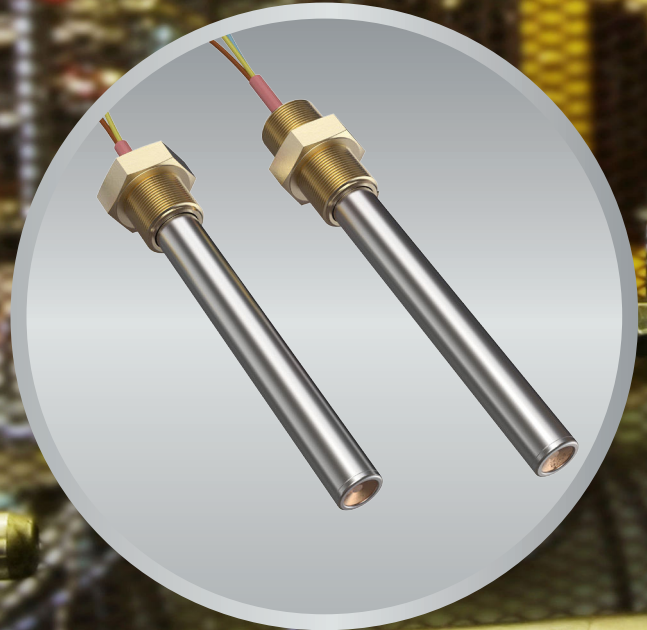

(1-800-492-8826)

www.wattco.com

CARTRIDGE HEATERS

component parts

OVERVIEW

WATTCO™ cartridge heaters are made of a swaged construction that consists in a high-grade nickel chromium resistance wire wound around a high-quality MgO core that is centered in a stainless steel casing.

Cartridge heaters are used for several heating metal parts and can be fitted with threaded bushings for liquid heating for certain applications. Cartridge heaters will reach metal temperatures of up to 1400°F (760°C) with the appropriate material, watt density, and fit selections (see Figure 2 on Page 7.2). Maximize element life and value with WATTCO™ cartridge heaters.

KEY FEATURES

- » Main components:
 - o High-grade nickel chromium resistance wire
 - o MgO core
 - o Stainless steel casing
 - o Stranded leads with silicon-impregnated mica glass insulation
- » Special sizes, wattages, and materials are available upon request.

BENEFITS

- » Easy and economical to install
- » Designed with first-class materials
- » Maximized heat transfer
- » Easy to maintain
- » Uniform temperatures
- » Built solidly
- » Oxidation and corrosion resistant
- » Durable

SELECTING WATTCO™ CARTRIDGE HEATER

The following sections will help you select the WATTCO™ cartridge heater that meets the requirements of your application.

NEED ASSISTANCE?

Please call us at 1-800-4WATTCO (1-800-492-8826) for further information or assistance.

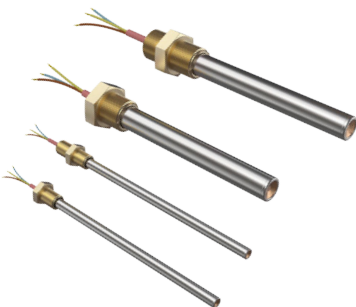

FACTORS

Please consider the following factors in order to select the right cartridge heater.

- » Operating temperature
- » Watt density of the heating element
- » Sheath material (corrosive or non corrosive)
 - o Temperature of the corrodent
 - o Degree of aeration of exposed corrodent
 - o Velocity of the corrodent

Please consult the following chart as a reference guide.

APPLICATIONS	SHEATH MATERIAL
Molds Metal dies Platens Hot plates Sealing tools Fluid heating Aerospace Semiconductor	Stainless Steel Incoloy® (available upon request, please consult factory)
Food service and medical equipment Deionized water	Stainless steel
General applications	Incoloy®
Highly corrosive applications	Titanium

Incoloy® is a registered trademark of Inco Alloys International

HOW TO INSTALL CARTRIDGE HEATER

- » Make a hole in the section that is to be heated (see Figure 2 to find out about proper hole diameter and tolerance).
- » Ream a smooth hole for contact and for better heat transfer.
- » Extend the hole through the section so that the unit can be driven out if you should need to remove it.
- » If making a through hole is impossible, increase the size of the hole without exceeding the tolerances shown in Figure 2.
- » Reduce the vibration and flexing of the lead wires to prolong service life.
- » Prevent contamination from liquids by protecting the end of the heater.

CARTRIDGE HEATERS

component parts

FIG. 2 - WATT DENSITY VS. FIT TOLERANCE AND WORK TEMPERATURE

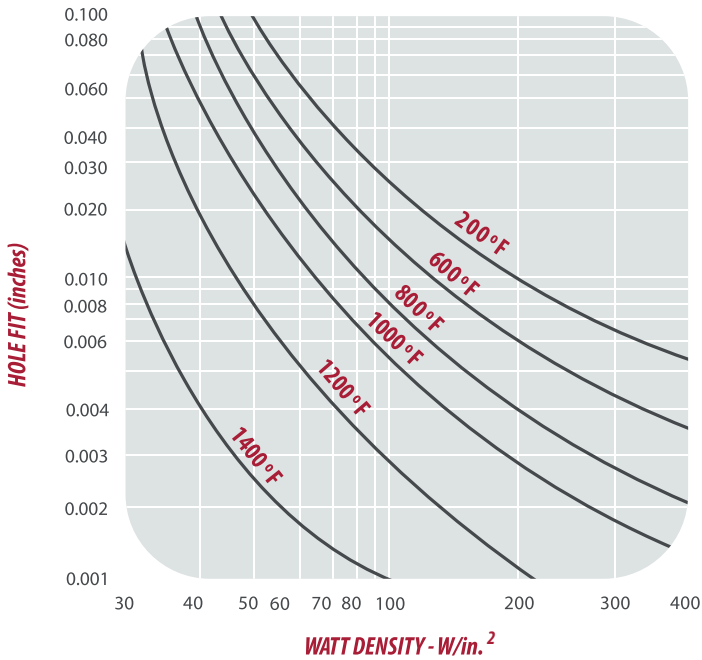
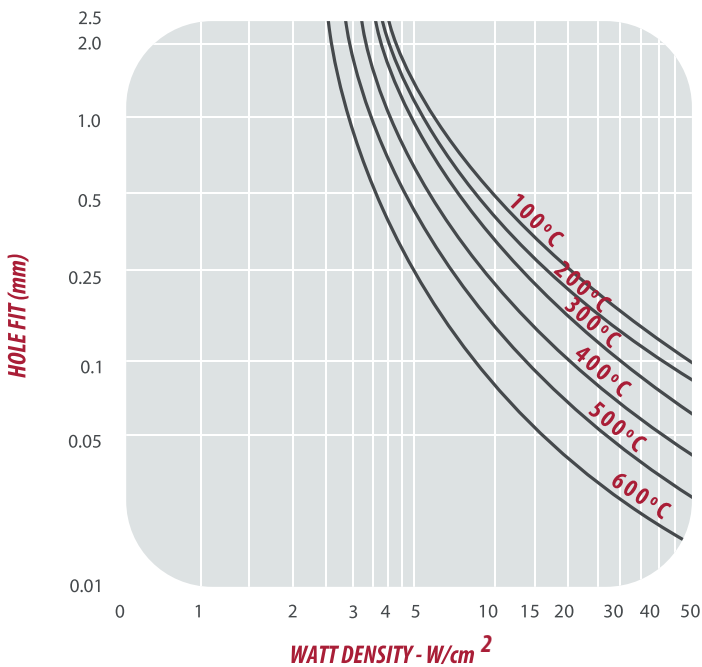

FIG. 3 - SUGGESTED WATT DENSITY FOR HEATING METAL PARTS



WHEN ORDERING, PLEASE SPECIFY: Quantity, catalogue number, tension, wattage, diameter, length of cartridge, length of lead, and extra features.

TOLERANCES

Please refer to this chart to learn more about the allowed manufacturing tolerances:

MANUFACTURING TOLERANCES	
Resistance tolerance	+ 10% - 5%
Wattage tolerance (at rated tension)	+5%, -10%
Diameter tolerance	±0.002"
Length tolerance	±1/16" or 1.5% of length
Maximum sheath temperature	1400°F



FIG. 4 - DETERMINING THE PROPER FIT

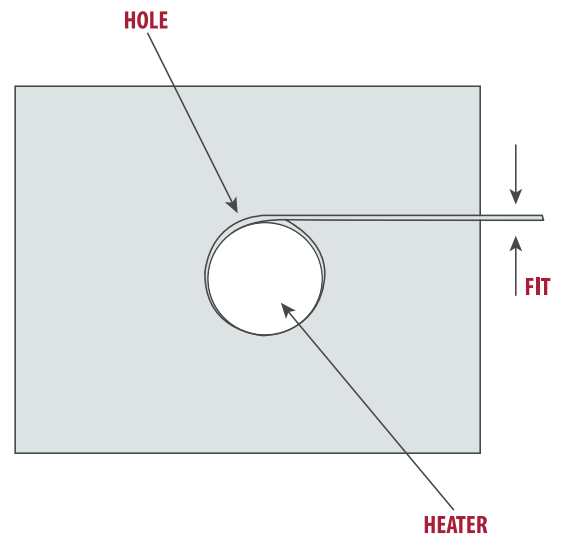

CARTRIDGE HEATERS

component parts



TABLE 1

Standard Watt Density Cartridge Heaters

Inches	SHEATH LENGTH Mm	CATALOG NUMBER	
		120 V	240V
¼ INCH HOLE DIAMETER (0.247 INCH SHEATH DIAMETER)			
1	25.4	WC20101	WC20102
1 ¼	31.8	WC201A1	WC201A2
1 ½	38.1	WC201C1	WC201C2
2	50.8	WC20201	WC20202
3	76.2	WC20301	WC20302
4	101.8	WC20401	WC20402
5	127.0	WC20501	WC20502
6	152.4	WC20601	WC20602
3/8 INCH HOLE DIAMETER (0.372 INCH SHEATH DIAMETER)			
1	25.4	WC30101	WC30102
1 ¼	31.8	WC301A1	WC301A2
1 ½	38.1	WC301C1	WC301C2
2	50.8	WC30201	WC30202
3	76.2	WC30301	WC30302
4	101.6	WC30401	WC30402
5	127.0	WC30501	WC30502
6	152.4	WC30601	WC30602
7	177.8	WC30701	WC30702
8	203.2	WC30801	WC30802
10	254.0	WC3101	WC3102
12	304.8	WC3121	WC3122
1/2 INCH HOLE DIAMETER (0.497 INCH SHEATH DIAMETER)			
1	25.4	WC50101	WC50102
1 ¼	31.8	WC501A1	WC501A2
1 ½	38.1	WC501C1	WC501C2
2	50.8	WC50201	WC50202
2 ½	63.5	WC502C1	WC502C2
3	76.2	WC50301	WC50302
3 ½	88.9	WC503C1	WC503C2
4	101.6	WC50401	WC50402
5	127.0	WC50501	WC50502
6	152.4	WC50601	WC50602
6 ½	165.1	WC506C1	WC506C2
7	177.8	WC50701	WC50702
8	203.2	WC50801	WC50802
9	228.6	WC50901	WC50902
10	254.0	WC51001	WC51002
12	304.8	WC51201	WC51202
14	355.6	WC51401	WC51402
18	457.2	WC51801	WC51802

CARTRIDGE HEATERS

component parts



TABLE 1

Standard Watt Density Cartridge Heaters

Inches	SHEATH LENGTH Mm	CATALOG NUMBER	
		120 V	240V
5/8 INCH HOLE DIAMETER (0.622 INCH SHEATH DIAMETER)			
1 ¼	31.8	WC601A1	WC601A2
1 ½	38.1	WC601C1	WC601C2
2	50.8	WC60201	WC60202
2 ½	63.5	WC602C1	WC602C2
3	76.2	WC60301	WC60302
3 ½	88.9	WC603C1	WC603C2
4	101.6	WC60401	WC60402
5	127.0	WC60501	WC60502
6	152.4	WC60601	WC60602
6 ½	165.1	WC606C1	WC606C2
7	177.8	WC60701	WC60702
8	203.2	WC60801	WC60802
9	228.6	WC60901	WC60902
10	254.0	WC61001	WC61002
12	304.8	WC61201	WC61202
14	355.6	WC61401	WC61402
18	457.2	WC61801	WC61802
20	508.0	WC62001	WC62002
36	914.4	WC63601	WC63602
3/4 INCH HOLE DIAMETER (0.747 INCH SHEATH DIAMETER)			
2 ¼	57.2	WC70201	WC70202
3	76.2	WC70301	WC70302
4	101.6	WC70401	WC70402
5	127.0	WC70501	WC70502
6	152.4	WC70601	WC70602
6 ½	165.1	WC706C1	WC706C2
7	177.8	WC70701	WC70702
8	203.2	WC70801	WC70802
9	228.6	WC70901	WC70902
10	254.0	WC71001	WC71002
12	304.8	WC71201	WC71202
14	355.6	WC71401	WC71402
18	457.2	WC71801	WC71802
20	508.0	WC72001	WC72002
36	914.4	WC73601	WC73602

CARTRIDGE HEATERS

component parts

EXTRA FEATURES AND MODIFICATIONS

EXTRA FEATURES	MODIFICATIONS
TENSIONS AND WATTAGES	WATTCO™ cartridge heaters can be custom build to suit other tensions and wattages upon request. Connecting series cartridges on line tensions of more than 300V is not recommended. Please call us at 1-800-4WATTCO (1-800-492-8826) for further details or assistance.
LENGTHS	WATTCO™ cartridge heaters can be specially configured to any length, up to 100 inches. With longer lengths, special equipment will be necessary for accurate drilling and reaming holes.
SHEATH MATERIALS	WATTCO™ standard cartridge heaters are made from grade 321 stainless steel. Should you need special requirements, please call us at 1-800-492-8826.
MOISTURE-RESISTANCE	WATTCO™ cartridge heaters are supplied with welded end cap that acts as a gas tight seal. The alternative options for lead wire construction are: <ul style="list-style-type: none"> » Silicon potting » Teflon seals » Teflon leads Please call us at 1-800-4WATTCO (1-800-492-8826) for assistance.
LEAD WIRE LENGTH	WATTCO™ cartridge heaters are supplied with standard 10" long fiberglass insulated nickel leads. Longer leads or spliced leads to stock units are available upon request.
PROTECTIVE LEAD COVERS	WATTCO™ provides cable or stainless steel braided sleeving for additional mechanical protection over the lead wires.
THERMOCOUPLE	Built-in J or K thermocouples are available for any WATTCO™ cartridge heater.
GROUND WIRE	For special code requirements, request that an additional ground wire be fixed to the sheath.
THREADED BUSHING	For immersed applications, request welded single-ended and double-ended stainless steel bushings. Please call us at 1-800-4WATTCO (1-800-492-8826) for density information.

WHEN ORDERING, PLEASE SPECIFY: Quantity, catalogue number, and extra features.

THREADED BUSHING (FIG. 1-2)

For liquid immersion heating applications under 750°F, use brass.

For applications over 750°F, use stainless steel.

CART. DIA.	A DIM. mm	B DIM. mm	STD. TAPER PIPE THD.	CART. DIA.	A DIM. mm	B DIM. mm	C DIM. mm	STD. TAPER PIPE THD.
1/4"	11.9	15.2	1/8" NPT	1/4"	11.9	24.8	9.6	1/8" NPT
3/8"	15.7	17.2	1/4" NPT	3/8"	15.7	27.6	10.4	1/4" NPT
1/2"	17.2	21.7	3/8" NPT	1/2"	17.2	35.6	13.9	3/8" NPT
5/8"	22.5	24.2	1/2" NPT	5/8"	22.1	38.2	16	1/2" NPT
3/4"	26.8	26.5	3/4" NPT	3/4"	26.8	43.2	16.7	3/4" NPT
1 19/64"	44.5	34.9	1 1/4" NPT	1 19/64"	44.5	60.3	25.4	1 1/4" NPT



FIG. 1

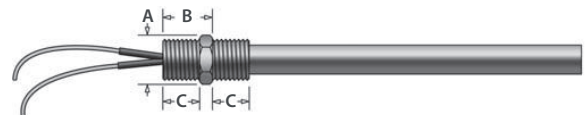

FIG. 2